

# TSSU-48-12-HC

Prep Table, 12x 1/6 Top Pans, 2 Solid Swing Doors



Dimensions		Build		Technical	
External Width (mm)	1229	Door Description	2 Solid Swing Doors	Temperature Holding	0.5 : 5°C
External Depth (mm)	766	Exterior Construction	Stainless steel front, top & hood, aluminium sides and rear	Refrigerant	R290
External Height (mm)	1093	Interior Construction	Clear coated aluminium, stainless steel base	Voltage / Frequency / Phase	220-240V/50-60Hz/1
Exclusions	Depth does not include 26 mm for rear bumpers. Height with lid closed.	Air Intake Position	Front	Amps	2.3
Gross Volume (Litres)	340	Ventilation Position	Front	Wattage	529
Supplied Shelves	4	Clearance Required	Zero back and sides	Defrost Type	Auto
Shelf Size (L x D mm)	Two 547 x 514 + Two 547 x 349	Cord Length (Meters)	3.35		
Internal Net Height (mm)	535	Standard w/ Locks	Not standard (SPEC3 option)		
Top Pans Supplied (depth mm)	12x 1/6 GN (100)				
Unpackaged Weight (kg)	121				
Packaged Weight (kg)	132				
Packaged Dimensions (W x D x H mm)	1302 x 833 x 1270				
Cutting Board (L x D mm)	1229 x 299				
Supplied with	ø 127 mm castors (158 mm height)				



Specifications subject to change without notice.  
Chart dimensions rounded up to the next whole millimeter (inches rounded up to the 1/8")

UK & Ireland [0800 783 2049](tel:08007832049)  
EMEA [+41 61 563 07 05](tel:+41615630705)  
Australia [+61 2 9619 9999](tel:+61296199999)

[TFIUK@truemfg.com](mailto:TFIUK@truemfg.com)  
[TrueCHCustomerService@truemfg.com](mailto:TrueCHCustomerService@truemfg.com)  
[TrueRefAus@truemfg.com](mailto:TrueRefAus@truemfg.com)



# TSSU-48-12-HC

■ Prep Table, 12x 1/6 Top Pans, 2 Solid Swing Doors

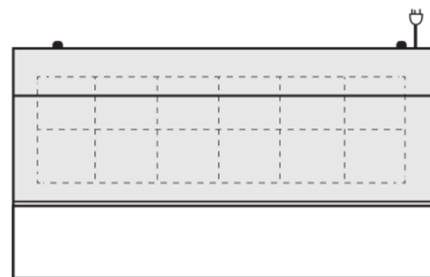
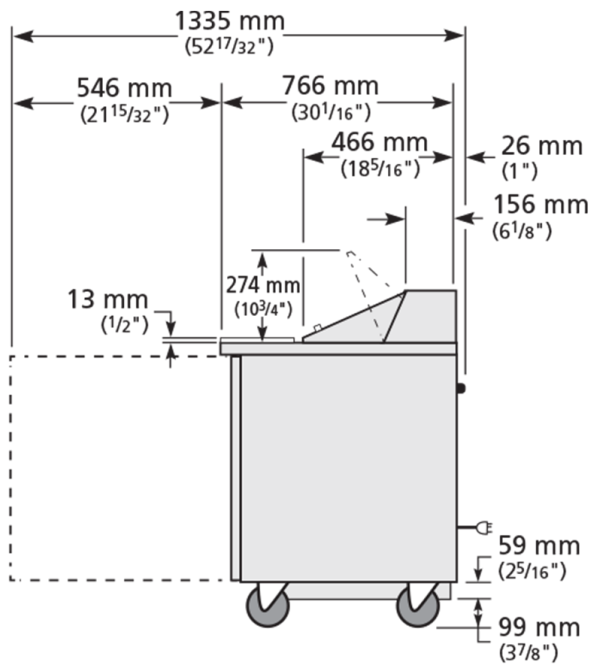
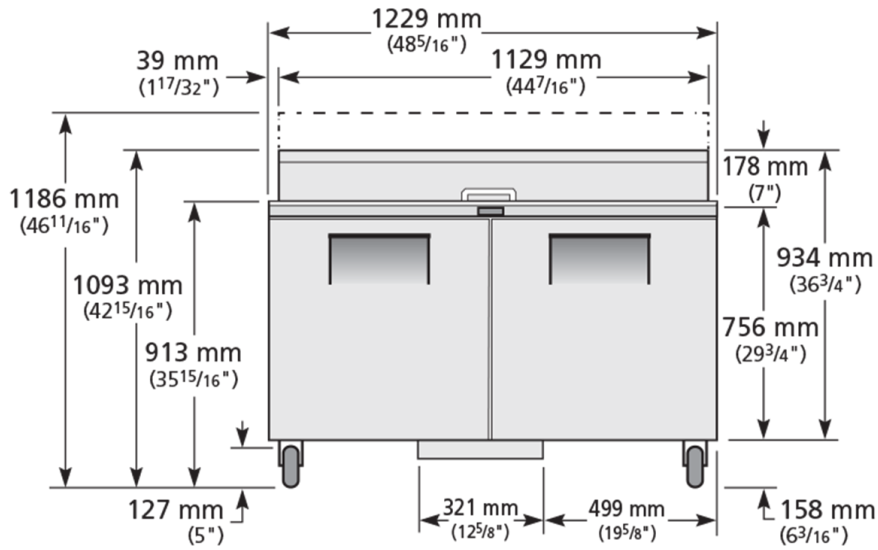

Specifications subject to change without notice.  
Chart dimensions rounded up to the next whole millimeter (inches rounded up to the 1/8")

UK & Ireland 0800 783 2049  
EMEA +41 61 563 07 05  
Australia +61 2 9619 9999

TFIUK@truemfg.com  
TrueCHCustomerService@truemfg.com  
TrueRefAus@truemfg.com

